

**USER MANUAL**  
**AGILENT ACQIRIS**  
**3-, 5-, AND 8-SLOT CPCI CRATES**

**Manual Part Number**

U1092-90018

**Edition**

D-RevB, June 2010

The information in this document is subject to change without notice and may not be construed in any way as a commitment by Agilent Technologies, Inc. While Agilent makes every effort to ensure the accuracy and contents of the document it assumes no responsibility for any errors that may appear.

All software described in the document is furnished under license. The software may only be used and copied in accordance with the terms of license. Instrumentation firmware is thoroughly tested and thought to be functional but it is supplied "as is" with no warranty for specified performance. No responsibility is assumed for the use or the reliability of software, firmware or any equipment that is not supplied by Agilent or its affiliated companies.

You can download the latest version of this manual from <http://www.agilent.com/> by clicking on Manuals in the Technical Support section and then entering a model number. You can also visit our web site at <http://www.agilent.com/find/acqiris>. At Agilent we appreciate and encourage customer input. If you have a suggestion related to the content of this manual or the presentation of information, please contact your local Agilent Acqiris product line representative or the dedicated Agilent Acqiris Technical Support ([ACQIRIS\\_SUPPORT@agilent.com](mailto:ACQIRIS_SUPPORT@agilent.com)).

**Acqiris Product Line Information**

USA (800) 829-4444

Asia - Pacific 61 3 9210 2890

Europe 41 (22) 884 32 90

© Copyright Agilent 2010

# CONTENTS

<b>1. OUT OF THE BOX</b>	<b>4</b>
1.1. Message to the User	4
1.2. Before Using Your Crate	4
1.3. Organization of This Manual	4
1.4. Conventions Used in This Manual	4
1.5. Disclaimer and Safety	5
1.6. Warning Regarding Medical Use	5
1.7. Packaging and Handling	5
1.8. Optional Equipment	6
1.8.1. Rack-mount Adapter	6
1.8.2. Handles for Rack Mounted	6
1.8.3. Carrying Handle and Feet	6
1.8.4. CompactPCI 6U to 3U Slot Adapter	7
1.8.5. Filler Plug-in	7
1.9. Warranty	7
1.10. Warranty and Repair Return Procedure, Assistance and Support	7
1.11. Transport & Shipping	8
1.12. Maintenance	8
1.13. Cleaning	8
1.14. Disposal and Recycling	8
<b>2. INSTALLATION</b>	<b>9</b>
2.1. Configuration	9
2.2. Site Considerations	10
2.3. Rack Mounting	10
2.4. AC Mains Power	10
2.4.1. Connecting to AC Mains Power	10
2.4.2. Fuse	10
2.5. Installing CompactPCI Modules	11
2.5.1. Installing 6U modules	11
2.5.2. Installing 3U modules	11
2.5.3. Installing Filler Plug-in	11
<b>3. SPECIFICATIONS</b>	<b>12</b>
3.1. Main Features	12
3.2. Power Supply	13
3.2.1. AC Input Specifications	13
3.2.2. DC Outputs Specifications	14
3.3. Slot Specifications	15
3.4. Backplane	16
3.4.1. Backplane Specifications	16
3.4.2. Power Supply Status	16
3.4.3. Connector Pinouts	17
3.5. Environmental	18
3.5.1. Environmental Specifications	18
3.5.2. Safety	18
3.5.3. EMC Immunity & Emissions	18
3.6. Mechanical	19
3.6.1. Mechanical Specifications	19
3.6.2. Dimensions	20
3.6.3. Rack Mounting Dimensions	21
<b>4. APPENDICES</b>	<b>22</b>
4.1. U1092A-C31 XC103 Rack-mount Adapter	22
4.2. U1092A-C51 XC105 Rack-mount Adapter	23
4.3. U1092A-C81 XC108 Rack-mount Adapter	24
4.4. XC114 – XC116 –XC119 Handles for Rack Mounted CC10X Crate Family	25
4.5. U1092A (U1056A)-C32 -C52 -C82 XC113 – XC115 –XC118 Handles and Feet	26
4.6. U1092A-C01 (U1056A-A10) XC100 6U to 3U Slot Adapter	27
4.7. U1092A-C02 (U1056A-A11) XC200 6U Filler Plug-in	28

# 1. OUT OF THE BOX

## 1.1. Message to the User

Congratulations on having purchased an Agilent Technologies Acqiris product. CC10X, crates use the highest quality components and high output power supplies in order to maximize system performance and reliability. These universally applicable CompactPCI crates are carefully designed to yield high performance test systems for bench, lab and manufacturing test applications.

## 1.2. Before Using Your Crate

This manual covers the entire family of Acqiris 6U CompactPCI crates. These crates differ in number of slots and in total usable power.

- U1091AC30 - Model CC103 CompactPCI crate with 3 slots.
- U1091AC50 - Model CC105 CompactPCI crate with 5 slots.
- U1091AC80 - Model CC108 low power, CC108, and CC108-600 CompactPCI crates with 8 slots.
- U1091AC83 - Model CC108-800 CompactPCI crates with 8 slots.

The terminology CC10X is used throughout this manual when descriptions or specifications relate to the entire family.

This User Manual describes the features of the CC10X crate and contains information for your safety, about configuring the crate, installing the modules, and operating the system.

## 1.3. Organization of This Manual

This manual is organized as follows :

- Chapter 1      ***OUT OF THE BOX***, gives information you must know prior to using CC10X crates, lists the contents of the box, lists optional equipment you can order from us, and describes the warranty and repair return procedure.
- Chapter 2      ***INSTALLATION***, describes how to prepare and operate your CC10X crate.
- Chapter 3      ***SPECIFICATIONS***, gives complete technical specifications of your CC10X crate.
- Chapter 4      ***APPENDICES***, gives specifications and assembly instructions supplied with the optional equipments.

## 1.4. Conventions Used in This Manual

The following conventions are used in this manual :



This icon to the left of text warns that an important point must be observed.

***WARNING***      Denotes a warning, which advises you of precautions to take to avoid being electrically shocked.

***CAUTION***      Denotes a caution, which advises you of precautions to take to avoid electrical, mechanical, or operational damages.

***NOTE***          Denotes a note, which alerts you to important information.

*Italic*          Italic text denotes a warning, caution, or note.

***Bold Italic***      Bold italicized text is used to emphasize an important point in the text or a note

## 1.5. Disclaimer and Safety

 **WARNING :** *The CC10X crate contains voltage hazardous to human life and safety, and is capable of inflicting personal injury. For your safety, before undertaking any troubleshooting or maintenance procedure, read carefully the WARNING and CAUTION notices.*

**Crate Grounding :** The CC10X crate requires a connection from the premises wire safety ground to the CC10X chassis ground to minimize shock hazard. This crate is designed with a three-position IEC320 C14 plug that connects the earth safety ground line to the chassis ground. ***A power cord with protective safety ground conductor must be used.*** The earth safety ground line must be always connected during use of this equipment. To minimize shock hazard, make sure your electrical power outlet has an appropriate earth safety ground that is connected whenever you power up the crate.

**Live Circuits :** Operating personnel must not remove protective covers when operating or servicing the CC10X crate. Adjustments and service to internal components must be undertaken by qualified personnel. During service of this product, the mains connector to the premise wiring must be disconnected. Dangerous voltages may be present under certain conditions, use extreme caution.

**Explosive Atmosphere :** Do not operate the crate in conditions where flammable gases are present. Under such conditions this crate is unsafe and may ignite the gases or gas fumes.

**Part Replacement :** Only service this crate with parts that are exact replacements, both electrically and mechanically. Installation of parts that are not exact replacements may cause harm to personnel operating the crate. Furthermore, damage or fire may occur if replacement parts are suitable.

**Modification :** Do not modify any part of the crate from its original condition. Unsuitable modifications may result in safety hazards.

**Lifting and Carrying:** An empty U1091AC83 (CC108-800) crate weighs up to 11.3 kg (25 lb). A fully loaded crate could weigh up to 23.3 kg (51 lb). Thus, either one person can lift or carry an empty crate or handles need to be attached and two persons have to manipulate a loaded crate. The smaller crates can be manipulated by one person.

 **WARNING :** *If an instrument handle is damaged, you should replace it immediately. Damaged handles can break while you are moving or lifting the instrument and cause personal injury or damage to the instrument.*

## 1.6. Warning Regarding Medical Use

The CC10X crates are not designed with components and testing intended to ensure a level of reliability suitable for use in treatment and diagnosis of humans. Applications of these crates involving medical or clinical treatment can create a potential for accidental injury caused by product failure, or by errors on the part of the user. These crates are **not** intended to be substitute for any form of established process or equipment used to monitor or safeguard human health and safety in medical treatment.

 **WARNING :** *The modules discussed in this manual have not been designed for making direct measurements on the human body. Users who connect an Acqiris module to a human body do so at their own risk*

## 1.7. Packaging and Handling

After carefully unpacking all items, inspect each to ensure there are no signs of visible damage. Check to make sure that all hardware and the switch are undamaged. Inspect the inner chassis for any possible damage, debris, or detached components. If damage appears to have been caused in shipment, file a claim with the carrier. Also check that all the components received match those listed on the enclosed packing list. Agilent cannot accept responsibility for missing items unless we are notified promptly of any discrepancies. If any items are found to be missing or are received in a damaged condition please contact the Agilent service center or your local supplier immediately. Retain the box and packing materials for possible inspection and/or reshipment.

Verify that you have received the following items with your CC10X crate :

- Power cord

Power Cord	Rating	Reference Standards
Universal Europa	250V/10A	CEE7 sht/IEC320 C13
North America	125V/10A	NEMA 5-15/IEC320 C13
United Kingdom	250V/10A	BS1363A/IEC320 C13

Italy	250V/10A	CIE 23-16/IEC320 C13
Switzerland	250V/10A	SEV1011/IEC320 C13

- User Manual: Agilent Acqiris 3-, 5-, and 8-slot cPCI Crates
- A compact disc in an Agilent Technologies paper CD envelope that includes
  - 10 product User Manuals in electronic form (8-bit Digitizers, 10-bit Digitizers, 12-bit Digitizers, Averagers, Analyzers, Signal Analyzers, Streamer Analyzers, Time-to-Digital Converters, 3-, 5-, and 8-slot CompactPCI Crates, and the 21-slot CompactPCI Crate),
  - 1 Programmer's Guide and 1 Programmer's Reference Manual,
  - device drivers with sample software for different operating systems, environments and languages,
  - the Analyzer Demo application, a demonstration program for the AC/SC Analyzer products,
  - the AcqirisLive application, a demonstration program for our digitizer and averager products,
  - the SSR Demo application, a demonstration program for the Acqiris AP235/AP240 Analyzers,
  - the APX01 Demo application, a demonstration program for the Acqiris AP101/AP201 Analyzers,
  - the TC Demo application, a demonstration program for the Acqiris TC840/TC842/TC890 Time-to-Digital Converters,
  - full installation procedures for use with Microsoft Windows, National Instruments LabVIEW RT, Wind River VxWorks, IVI-COM/C, and Linux software.
- For many products a declaration of conformity is still included. However, in an increasing number of cases the Declaration can be viewed at <http://www.agilent-pra.com>.
- Optional equipment. See the enclosed packing list.

## 1.8. Optional Equipment

### 1.8.1. Rack-mount Adapter

The following optional rack-mount kits are available from Acqiris :

- **U1092A-C31 XC103 RACK-MOUNT ADAPTER** for CC103 crate. Height 3U (132.5mm).
- **U1092A-C51 XC105 RACK-MOUNT ADAPTER** for CC105 crate. Height 4U (177mm).
- **U1092A-C81 XC108 RACK-MOUNT ADAPTER** for CC108 crate. Height 5U (221.4mm).

Each adapter allows the mounting of the crate in a standard 19inch (483mm) instrumentation rack, with the adapter attached to either the front or the rear of the crate.

For further information, refer to the appendix 4.1., 4.2. and 4.3. *Rack-mount Adapter* assembly instructions.

### 1.8.2. Handles for Rack Mounted

They optional handles are designed for use with the rack-mount adapters. They make it easy to carry the crate and to mount it in the instrumentation rack. They can be left on the crates permanently since they do not interfere with the cooling air circulation.

- **XC114 Handles for Rack Mounted** for CC103 crate equipped with XC103 rack-mount adapter.
- **XC116 Handles for Rack Mounted** for CC105 crate equipped with XC105 rack-mount adapter.
- **XC119 Handles for Rack Mounted** for CC108 crate equipped with XC108 rack-mount adapter.

For further information, refer to the appendix 4.4. **XC114 – XC116 –XC119 HANDLES FOR RACK MOUNTED CC10X CRATE FAMILY** assembly instructions.

### 1.8.3. Carrying Handle and Feet

When these optional handle and feet assemblies are installed it is safe and easy to carry the crates and to stand them on their sides. They can be left on the crates permanently since they do not interfere with the cooling air circulation.

**WARNING**, the CC10X family crates have not been designed to function when they are standing on their sides, users must accept the responsibility for using in that position.

- *U1092A (U1056A)-C32 XC113 Handle and Feet Assembly* for CC103 crate.
- *U1092A (U1056A)-C52 XC115 Handle and Feet Assembly* for CC105 crate.
- *U1092A (U1056A)-C82 XC118 Handle and Feet Assembly* for CC108 crate.

For further information, refer to the appendix 4.5. *U1092A (U1056A)-C32 -C52 -C82 XC113 – XC115 –XC118 Handles and Feet* specifications and assembly instructions.

#### **1.8.4. CompactPCI 6U to 3U Slot Adapter**

The optional *U1092A-C01 (1056A-A10) XC100 Slot Adapter* is specially designed for use with CC10X crates. This CompactPCI slot adapter allows the use of 3U modules in any vacant 6U slots. The XC100 assures proper mechanical alignment when inserting a 3U module and protects the crate's backplane connectors from damage. In addition, the XC100 meets the IEEE 1011.10 standard and provides the function of a filler panel to completely close the half vacant slot. This function is essential to guarantee EMC performance and appropriate cooling.

For further information, refer to the appendix 4.6 *U1092A-C01 (U1056A-A10) XC100 6U TO 3U SLOT Adapter* specifications and assembly instructions.

#### **1.8.5. Filler Plug-in**

An optional *U1092A-C02 (U1056A-A11) XC200 Filler Plug-in* is available from Acqiris. This 6U CompactPCI plug-in (width 1 slot) meets the IEEE 1011.10 standard and implements the function of a filler panel that completely closes the front of the unused slots and reduces the cross-flow air circulation. This function is essential to guarantee EMC performance and appropriate cooling.

For further information, refer to the appendix 4.7 *U1092A-C02 (U1056A-A11) XC200 6U FILLER Plug-in* specifications and assembly instructions.

### **1.9. Warranty**

All Agilent Acqiris Digitizer products are warranted to operate within specification, assuming normal use, for a period of at least one year from the date of shipment. Units sold before April 2008 had three year warranties, as do some more recent ones; in case of doubt examine your invoice. It is recommended that yearly calibration be made in order to verify product performance. All repairs, replacement and spare parts are warranted for a period of 3 months. Warranty extensions are available as an option.

In exercising this warranty, Agilent will repair or replace any product returned to the Agilent service center, within the warranty period. The warranty covers all defects that are a result of workmanship or materials. This excludes defects that are caused by accident, misuse, neglect, or abnormal operation.

The purchaser is responsible for returning the goods to the nearest Agilent service center. This includes transportation costs and insurance. Agilent will return all warranty repairs with transportation prepaid.

### **1.10. Warranty and Repair Return Procedure, Assistance and Support**

Agilent acquired Acqiris SA and its product lines in December 2006. Please contact your nearest Agilent Service Center before returning any product for repair.

You can find information about technical and professional services, product support, and equipment repair and service on the Web, see <http://www.agilent.com/find/service> (or <http://www.agilent.com/> and after selecting your country click on **Contact Us**). The service center will ask for your name, company, phone number and address, the model and serial numbers of the unit to be repaired, and a brief description of the problem.

Before issuing a Service Order the service center may ask you to communicate with us by phone or eMail so that we can learn as much as needed about the problems observed. If a unit returned under guarantee is found to be working normally and this procedure was not followed we reserve the right to charge you for the work done.

For your nearest customer support center please contact Acqiris Technical Support ([ACQIRIS\\_SUPPORT@agilent.com](mailto:ACQIRIS_SUPPORT@agilent.com)) or come visit our web site at <http://www.agilent.com/find/acqiris>. Alternatively, contact Acqiris at 1-800-829-4444 in the USA, +41 22 884 32 90 in Europe or +61 3 9210 2890 in the Asia-Pacific region. The Agilent Support Centers can also help redirect you for any questions concerning the installation and operation of your equipment.

## 1.11. Transport & Shipping

To package the instrument for shipping:

### Step

1. Place the instrument in its original packaging materials.
2. Surround the instrument with at least 3 to 4 inches (8 to 10 cm) of its original packing material or bubble-pack to prevent the instrument from moving in its shipping container.
3. After wrapping it with packing material, place the instrument in its original shipping container or a strong shipping container that is made of double-walled corrugated cardboard with 159 kg (350 lb) bursting strength.
4. Seal the shipping container securely with strong nylon adhesive tape.
5. Mark the shipping container "FRAGILE, HANDLE WITH CARE" to help ensure careful handling.
6. Use the address obtained from your Agilent Technologies Service Center.
7. Retain copies of all shipping papers.

### Notes

- If the original packaging materials are not available, use a professional packaging service. Contact your Agilent Service Center for more information.
- The shipping container must be large and strong enough to accommodate your instrument and allow at least 3 to 4 inches (8 to 10 cm) on all sides for packing material.



**CAUTION:** *Damage can result if the original packaging materials are not used. Packaging materials should be anti-static and cushion the instrument on all sides. NEVER USE STYRENE PELLETS IN ANY SHAPE AS PACKAGING MATERIALS. They do not adequately cushion the instrument or prevent it from moving in the shipping container. Styrene pellets can also cause equipment damage by generating static electricity or by lodging in fan motors.*

## 1.12. Maintenance

The CC10X crates do not require any maintenance. There are no user serviceable parts inside.

## 1.13. Cleaning



**WARNING:** *Always power off the crate and disconnect the power cord before cleaning the crate.*

Cleaning procedures consist only of exterior cleaning.

Clean the exterior surfaces of the crate with a dry lint-free cloth or a soft-bristle brush. If any dirt remains, wipe a cloth moistened in a mild soap solution. Remove any soap residue by wiping with a cloth moistened with clear water. Do not use abrasive compounds on any part of the crate.



**CAUTION:** *Avoid getting moisture inside the crate during exterior cleaning. Use just enough moisture to dampen the cloth.*

*Do not wash the connector and switches. Cover these components while cleaning the crate.*

*Do not use chemical cleaning agents, they may damage the crate. Avoid chemicals that contain benzene, toluene, xylene, acetone, or similar solvents.*

## 1.14. Disposal and Recycling

Electronic equipment should be properly disposed of. Acqiris crates must not be thrown out as normal waste. Separate collection is appropriate and may be required by law.





## 2. INSTALLATION

### 2.1. Configuration



**WARNING :** Before connecting the crate to a power source, read this chapter and the paragraph 1.5.

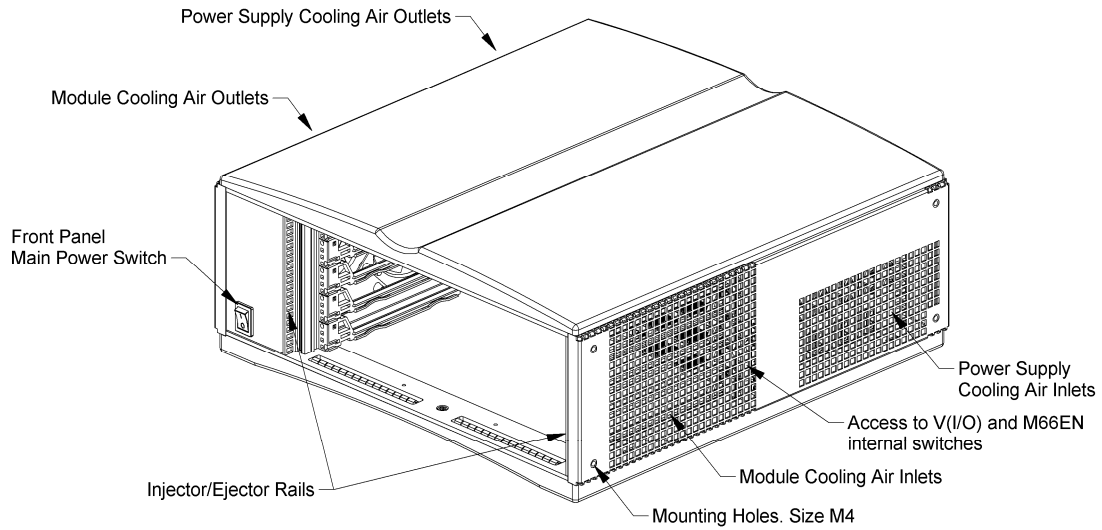

Figure 2.1: Front view of the CC105

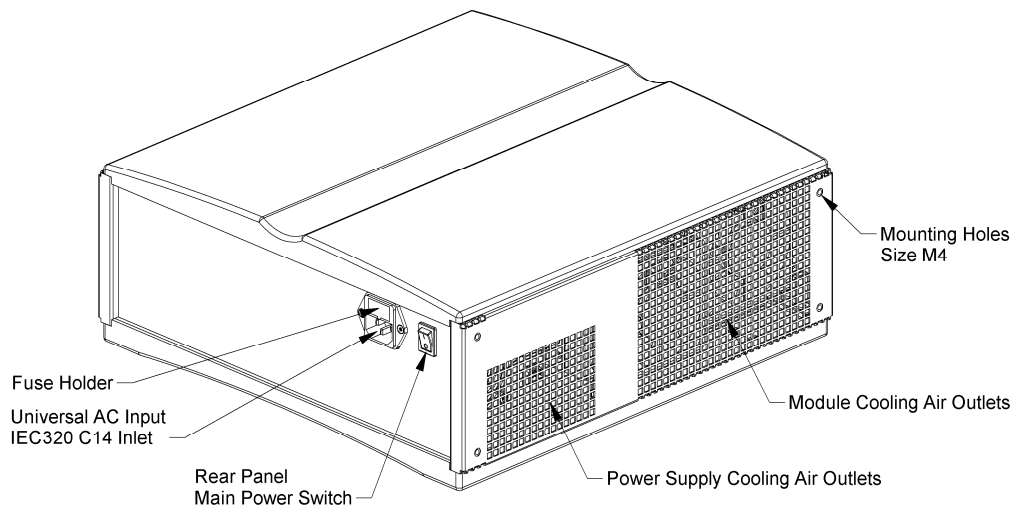



Figure 2.2: Rear view of the CC105

## 2.2. Site Considerations

The CC10X is designed to operate on a bench-top or in an instrument rack. Determine how you want to use your crate and follow the appropriate installation instructions.

 **WARNING:** *CC10X crates are not designed to operate vertically on the bench. In this position, the bottom air outlets are blocked and cooling is not assured. Also small objects can fall in the upper air inlets and create an electrical shock hazard.*

*When the optional carrying handles and feet XC113, XC115 or XC118 are installed, it is very important to read the appendix 4.5 and to respect the instructions of safety.*

The apertures along both sides of the crate allow power supply and modules cooling. Air enters through inlets located on right side of the crate and exits through the outlets on the left.

 **CAUTION:** *Keep other equipment a minimum of 75mm (3in.) away from the air inlets and outlets.*

## 2.3. Rack Mounting

Rack mounting applications require an optional rack-mount adapter with or without optional handles. These adapter and handles allows the mounting of the crate in a standard 19inch instrumentation rack.

CC10X crates have two sets of taped holes allowing the rack-mount adapter to be fixed either at the front or at the rear of the crate. This flexibility is provided to permit the wiring of signal cables from the front or from the back of the instrumentation rack. Mains switching has also been duplicated with one switch located on the front panel and an other one on the rear panel of the CC10X.

For further information, refer to the paragraph 3.6.3 *Rack Mounting Dimensions* and appendix 4.1, 4.2, 4.3 and 4.5 *Specifications and Assembly Instructions*.

## 2.4. AC Mains Power

### 2.4.1. Connecting to AC Mains Power

 **CAUTION:** *Make sure that one, or both, main power switches are in the 0 position (OFF) before connecting the power cord to AC mains power.*

The front and rear panel main switches are serially connected. Both switches must be **1 (ON)** to turn on the power supply, and they can be used independently to turn on or set off the crate.

The power supply is universal, which means the crate can connect to all standard worldwide input voltages. Attach input power through the rear panel AC Line inlet using the appropriate power cord supplied. Refer to the paragraph 1.7. *Packaging and Handling* for the power cord specification.

### 2.4.2. Fuse

 **WARNING:** *Disconnect the power cord before replacing the fuses.*

There are two cases.

- The power-line fuses are located within the crate's power cord assembly on the rear panel. The correct value of the fuses for all line voltages is the following :

CC103	5x20mm slow-blow fuse: T 4A H 250V	Acqiris PN: EF010400A
CC105 and CC108 low power	5x20mm slow-blow fuse: T 6.3A H 250V	Acqiris PN: EF010630A
CC108 and CC108-600	5x20mm slow-blow fuse: T 10A H 250V	Acqiris PN: EF011100A

 **WARNING:** *The value of the F1 and F2 power line fuses depend of the AC power input voltage. For safety reasons, please follow the instructions shown in the table below. Disconnect the power cord before replacing the fuses.*

- The CC108-800 is different than the models above. It is equipped with F1 and F2 power-line fuse-holders located on the rear panel. The correct values depend on the line voltages as follows:

<b>85 – 132 VAC</b>	5x20mm slow-blow fuse: T 10A H 250V	Acqiris PN: EF011160A
<b>190 – 264 VAC</b>	5x20mm slow-blow fuse: T 6.3A H 250V	Acqiris PN: EF010800A

In both cases, to replace the fuses, remove the power cord and take out the fuse holder. For continued protection against fire hazard, replace only with a fuse of the same type and rating.

## 2.5. Installing CompactPCI Modules



**CAUTION:** Turn off the crate power before installing or removing CompactPCI modules.

**NOTE:** The crate controller must be placed in the **System Slot** (slot1) located at the bottom of the crate. The System Slot is identified with the number 1 surrounded with a triangle. All other modules are to be located in any of the **Peripheral Slots** that are identified with their respective number surrounded with a circle.

Accepts PXI modules, but does not provide PXI-specific features (Local Bus, Trigger Bus, System Reference Clock).

The CC10X crates accept 6U as well as 3U modules thanks to the unique XC100 Slot Adapter.

### 2.5.1. Installing 6U modules

Install a module into the crate slot by first placing the module's card edges into the front module guides (left and right). Place both injector/ejector handles in the open position and slide the module to the rear of the crate. When you begin to feel resistance, push simultaneously both injector/ejector handles towards the center to plug the module into the backplane connectors of the crate. Secure it by clipping the handles into place. Tighten both front panel mounting screws to lock the module into place and insure proper grounding of the frame.

### 2.5.2. Installing 3U modules



**CAUTION:** The XC100 6U to 3U Slot Adapter must be installed prior to inserting any 3U module into the CC10X crate. The XC100 is necessary to guide the 3U module and avoid damaging backplane connectors.

Insert the XC100 into the module guide of the left part of the 6U slot. Turn the front panel knob in the clockwise direction to fasten the slot adapter into place. Tighten its front panel screw to insure proper grounding of the frame.

**NOTE:** Refer to the appendix 4.6 U1092A-C01 (U1056A-A10) XC100 6U TO 3U SLOT Adapter, Specifications and Assembly Instructions.

Install a 3U module into the crate slot by first placing the module's card edges into the left and right guides. Place the injector/ejector handle in the open position and slide the module to the rear of the crate. When you begin to feel resistance, push left on the handle to plug the module into the backplane connectors of the crate. Secure it by clipping the handle into place. Tighten both front panel mounting screws to lock the module into place and insure proper grounding of the frame.

### 2.5.3. Installing Filler Plug-in



**CAUTION:** The CC10X crate should not be used without closing all unused or empty slots.

To guarantee EMC performance and adequate cooling, install an optional XC200 Filler Plug-in or other filler panels conform to IEEE1101.10 into unused slots. Tighten both captive mounting screws to lock the panel into place and insure proper grounding of the frame.

**NOTE:** Refer to the appendix 4.7 U1092A-C02 (U1056A-A11) XC200 6U FILLER Plug-in, Specifications and Assembly Instructions.

## 3. SPECIFICATIONS

### 3.1. Main Features

The main features of the CC10X series include :

- 3, 5, and 8 slot versions. They have horizontal slot orientation with a **System Slot** at the bottom and 2, 4, or 7 **Peripheral Slots** above.
- CompactPCI (PICMG 2.0 R2.1) 6U and 3U module compatibility. The Backplane is equipped with P1 and P2 connectors. A CompactPCI 3U module must be used with the optional XC100 Slot Adapter. The crate accepts PXI modules, but does not provide PXI-specific features.
- Internal switch with locking lever for selection of V(I/O) to 5V or 3.3V. The standard version is shipped with V(I/O) set to 5V and 5V brilliant blue coding keys. On request we can deliver the crate with V(I/O) set to 3.3V and 3.3V cadmium yellow coding keys.
- Optimized cross-flow air circulation. Power supply and module slots are fully protected against over-temperature.
- Compact design for bench-top and rack-mount installation with the optional rack-mount adapter. The rack-mount adapter can be placed to either the front or the rear of the crate.
- Front and rear panel main power switches for easy access.
- Meets to IEEE 1101.10 standard for EMC compatibility and optimized cooling.
- Quality 270W, 400W, 600W, or 800W usable power supply with universal AC input, power factor correction, auto-voltage and auto-frequency ranging.
- **Derating** (DEG) and **Supply Fall** (FAL) signals provided from the power supply to backplane **System Slot** (P2 connector).
- Tilt feet for bench-top application.
- 66 MHz operation supported for the 3 and 5 slot versions ONLY.
- Internal switch for selection of forced 33 MHz PCI operation or choice of 33 MHz / 66 MHz based on modules present.

## 3.2. Power Supply

### 3.2.1. AC Input Specifications

AC Input Voltage and Frequency Ranges	Universal Auto-Frequency Ranging Input: 100 - 120 V~ : 50/60/400 Hz 220 - 240 V~ : 50/60 Hz
Maximum Input Power	<b>CC103</b> : 400W <b>CC105</b> : 600W <b>CC108 low power</b> : 600W <b>CC108 and CC108-600</b> : 900W <b>CC108-800</b> : 1000W for 100-120 V 1200W for 220-240 V
Power Factor Correction	Meets EN61000-3-2. Power Factor 0.95 minimum
Efficiency	75% typical @ full load
Holdover Storage	20msec minimum @ full load. Independent of AC input voltage.
AC Input Fuse	Located within the fuse-holder on the rear panel. All Fuses are Slow-Blow 5x20mm  <b>CC103</b> : T 4A H 250V <b>CC105</b> : T 6.3A H 250V <b>CC108 low power</b> : T 6.3A H 250V <b>CC108 and CC108-600</b> : T 10A H 250V <b>CC108-800</b> : T 10A H 250 V for 100-120 V T 6.3A H 250 V for 220-240 V
AC Input Inlet	IEC320 C14
Main Power Switches	2 switches in series: on the front and rear panels
Internal Fuse (F401)	Type ABC manufactured by Bussman or type 314 manufactured by Littelfuse.  <b>CC103, CC105, CC108 low power</b> : 10A, 250V <b>CC108 and CC108-600</b> : 15A, 250V <b>CC108-800</b> : 10A, 250V for each supply
Power Supply Cooling	Internal DC Fan. The airflow direction is from the right to the left side of the crate.

### 3.2.2. DC Outputs Specifications

Maximum Usable Power	<b>CC103:</b> 270W <b>CC105:</b> 400W <b>CC108 low power:</b> 400W <b>CC108 and CC108-600:</b> 600W <b>CC108-800:</b> 600W for 100-120 V 800W for 220-240 V
Output Voltages	<b>+3.3V:</b> +3.3 $\pm$ 0.1V, +0.15 V <b>+5V:</b> +5.1 $\pm$ 0.1V <b>+12V:</b> +12.15 $\pm$ 0.15V <b>-12V:</b> -12.15 $\pm$ 0.15V
Maximum Output Currents	<b>CC103, CC105, CC108 low power and CC108:</b> <b>+3.3V:</b> 60A (198W) <b>+5V:</b> 35A (175W) <b>+12V:</b> 17A (204W) <b>-12V:</b> 17A (204W)  <b>CC108-600:</b> <b>+3.3V:</b> 60A (198W) <b>+5V:</b> 60A (300W) <b>+12V:</b> 9A (108W) <b>-12V:</b> 4A (48W)  <b>CC108-800:</b> <b>+3.3V:</b> 120A(396W) with P(+3.3)+P(+12)< 400 W <b>+5V:</b> 80A (400W) with P(-12)+P(5)< 400 W <b>+12V:</b> 17A (204W) <b>-12V:</b> 17A (204W)
RMS Ripple	0.1% or 10mV whichever is greater. 20MHz bandwidth
Peak to Peak Noise	1% or 50mV whichever is greater. 20MHz bandwidth
Dynamic Response	<2% or 100mV @ 25% load step
Recovery Time	To within 1% in <0.3msec
Over-Current Protection	All outputs are protected from short circuit and overload. Automatic recovery.
Over-Voltage Protection	<b>3.3V and 5V:</b> 122-134% <b>+12V and -12V:</b> 110-120%. Turn OFF the crate to reset the Over Voltage Protection.
Thermal Protection	All outputs are disabled when the power supply internal temperature exceeds safe operating range. Warning signal (DEG#) >5msec before shutdown. Automatic recovery.

### 3.3. Slot Specifications

Slots	<p>Height: 6U, Width: 20.32mm (0.8 in.).  <b>CC103:</b> 3 slots (1 System Slot, 2 Peripheral Slots).  <b>CC105:</b> 5 slots (1 System Slot, 4 Peripheral Slots).  <b>CC108:</b> 8 slots (1 System Slot, 7 Peripheral Slots).</p>	
Module Cooling System	<p>Forced air circulation separated from the power supply cooling. Slot airflow direction from the bottom to top of the modules.  <b>CC103:</b> two 9 l/s (19 cfm) axial fans.  <b>CC105:</b> two 15 l/s (32 cfm) axial fans.  <b>CC108:</b> four 15 l/s (32 cfm) axial fans.  <b>CC108-800:</b> four 22 l/s (47 cfm) axial fans.  Module cooling inlets on the right side of the crate and outlets on the left side.</p>	
Airflow per Slot	<p>Typical 5 l/s (10.6 cfm).  Velocity 2 m/s (400 lfm) @ 70% cross-section aperture.</p>	
Cooling Capacity	<p>To be respected to ensure that the slot does not exceed the safe operating temperature  <b>CC103:</b> 3 slots 150W @ 50°C or 270 W @ 30°C.  <b>CC105:</b> 5 slots 250W @ 50°C or 400 W @ 30°C.  <b>CC108:</b> 8 slots 400W @ 50°C or 600 W @ 30°C.  <b>CC108-800:</b> 8 slots 400W @ 50°C or 800 W @ 30°C.</p>	
Slots Thermal Protection	<p>Separated from the power supply thermal protection. All power supply outputs are shutdown when the slot environment exceeds safe operating temperature (60°C). Warning signal (FAL#) &lt;4msec after the beginning of the shutdown.  Automatic recovery.</p>	
Per Slot Current Capacity	<p>See paragraph 3.4.1 Working Currents.</p>	
Maximum Module Weight	<p>1.5 kg (3.3 lb.)</p>	
Slot Numbering Convention CC103 implements Physical 1-3 CC105 implements Physical 1-5 CC108 implements Physical 1-8	Physical	Logical (decimal)
	1	4
	2	15
	3	14
	4	13
	5	12
	6	11
	7	10
	8	9

### 3.4. Backplane

#### 3.4.1. Backplane Specifications

Conformity	PICMG 2.0 R2.1
Size	Height 3U: P1 and P2 connectors (32/64 bit). <b>CC103:</b> 3 slots <b>CC105:</b> 5 slots <b>CC108:</b> 8 slots
System Slot	Left side (bottom)
GND (Common Return Outputs)	Floating. Connected to Chassis Ground with an 100kOhm resistor in parallel with >60nF capacitor.
V(I/O) Voltage and Coding Keys <b>Important:</b> V(I/O) should not be modified without changing the coding keys	<b>V(I/O):</b> internal switch selectable <b>Standard:</b> position <b>5</b> , connected to +5V with 5V brilliant blue coding key assembled <b>On request:</b> position <b>3.3</b> , connected to 3.3V with 3.3V cadmium yellow coding key assembled
Material	FR4: UL 94V0 recognized
Connectors P1 (Module A) and P2 (Module B)	Conforms to IEC917 and IEC 1076-4-101. UL 94V0 rated.
Working Currents	1.5A@25°C max per contact (1.2A@50°C). Power supply contacts per slot, connectors P1 and P2: <b>+3.3V:</b> P1; 10 contacts <b>+5V:</b> P1; 8 contacts <b>+12V:</b> P1; 1 contact <b>-12V:</b> P1; 1 contact <b>V(I/O):</b> P1; 5 contacts P2; 6 contacts <b>GND:</b> P1; 14 contacts P2; 18 contacts
Bus Frequency (66 MHz operation is supported for the 3 and 5 slot versions ONLY)	Internal switch selectable: Position <b>33</b> : 33 MHz only (M66EN grounded) Position <b>66</b> : 33 MHz or 66 MHz (M66EN open)

#### 3.4.2. Power Supply Status

The **Derating** (DEG#) and **Supply Fail** (FAL#) are implemented only for the System Slot.

Levels	TTL (0 = <0.8V, 1 = >2V)
DEG# Mains AC accurate signal	Indicate that the power supply is beginning to derate its power outputs. 1 = Mains AC is accurate. 0 to 1: 400msec minimum before FAL#. 1 to 0: 20msec minimum before FAL# and DC outputs shutdown.
FAL# Global DC outputs accurate signal	Indicate that an DC output from the power supply has a failure. 1 = All DC outputs are accurate. 0 to 1: 20msec minimum after the DC outputs are accurate. 1 to 0: 4msec maximum after the start of the DC output shutdown.



### 3.4.3. Connector Pinouts

Connector	Pin	Z	A	B	C	D	E	F	
P2 (J2)	22	GND	GA4	GA3	GA2	GA1	GA0	GND	
	21	GND	CLK6	GND	RSV	RSV	RSV	GND	
	20	GND	CLK5	GND	RSV	GND	RSV	GND	
	19	GND	GND	GND	RSV	RSV	RSV	GND	
	18	GND	BRSVP2A18	BRSVP2B18	BRSVP2C18	GND	BRSVP2E18	GND	
	17	GND	BRSVP2A17	GND	PRST#	REQ6#	GNT6#	GND	
	16	GND	BRSVP2A16	BRSVP2B16	DEG#	GND	BRSVP2E16	GND	
	15	GND	BRSVP2A15	GND	FAL#	REQ5#	GNT5#	GND	
	14	GND	AD[35]	AD[34]	AD[33]	GND	AD[32]	GND	
	13	GND	AD[38]	GND	V(I/O)	AD[37]	AD[36]	GND	
	12	GND	AD[42]	AD[41]	AD[40]	GND	AD[39]	GND	
	11	GND	AD[45]	GND	V(I/O)	AD[44]	AD[43]	GND	
	10	GND	AD[49]	AD[48]	AD[47]	GND	AD[46]	GND	
	9	GND	AD[52]	GND	V(I/O)	AD[51]	AD[50]	GND	
	8	GND	AD[56]	AD[55]	AD[54]	GND	AD[53]	GND	
	7	GND	AD[59]	GND	V(I/O)	AD[58]	AD[57]	GND	
	6	GND	AD[63]	AD[62]	AD[61]	GND	AD[60]	GND	
5	GND	C/BE[5]#	GND	V(I/O)	C/BE[4]#	PAR64	GND		
4	GND	V(I/O)	BRSVP2B4	C/BE[7]#	GND	C/BE[6]#	GND		
3	GND	CLK4	GND	GNT3#	REQ4#	GNT4#	GND		
2	GND	CLK2	CLK3	SYSEN#	GNT2#	REQ3#	GND		
1	GND	CLK1	GND	REQ1#	GNT1#	REQ2#	GND		
P1 (J1)	25	GND	5V	REQ64#	ENUM#	3.3V	5V	GND	
	24	GND	AD[1]	5V	V(I/O)	AD[0]	ACK64#	GND	
	23	GND	3.3V	AD[4]	AD[3]	5V	AD[2]	GND	
	22	GND	AD[7]	GND	3.3V	AD[6]	AD[5]	GND	
	21	GND	3.3V	AD[9]	AD[8]	M66EN	C/BE[0]#	GND	
	20	GND	AD[12]	GND	V(I/O)	AD[11]	AD[10]	GND	
	19	GND	3.3V	AD[15]	AD[14]	GND	AD[13]	GND	
	18	GND	SERR#	GND	3.3V	PAR	C/BE[1]#	GND	
	17	GND	3.3V	SDONE	SBO#	GND	PERR#	GND	
	16	GND	DEVSEL#	GND	V(I/O)	STOP#	LOCK#	GND	
	15	GND	3.3V	FRAME#	IRDY#	GND	TRDY#	GND	
	12-14	KEY AREA							
	11	GND	AD[18]	AD[17]	AD[16]	GND	C/BE[2]#	GND	
	10	GND	AD[21]	GND	3.3V	AD[20]	AD[19]	GND	
	9	GND	C/BE[3]#	IDSEL	AD[23]	GND	AD[22]	GND	
	8	GND	AD[26]	GND	V(I/O)	AD[25]	AD[24]	GND	
	7	GND	AD[30]	AD[29]	AD[28]	GND	AD[27]	GND	
6	GND	REQ#	GND	3.3V	CLK	AD[31]	GND		
5	GND	BRSVP1A5	BRSVP1B5	RST#	GND	GNT#	GND		
4	GND	BRSVP1A4	GND	V(I/O)	INTP	INTS	GND		
3	GND	INTA#	INTB#	INTC#	5V	INTD#	GND		
2	GND	TCK	5V	TMS	TDO	TDI	GND		
1	GND	5V	-12V	TRST#	+12V	5V	GND		

Notes:

1. All pins are medium length (level 2) except on the connector P1 pin C16 which is long (level 3) and D15 which is short (level 1).
2. The following positions of connector P2 are implemented only on the System Slot: A1-3, A19-21, B2, B19-21, C1-3, C15-17, D1-3, D15, D17, E1-3, E15, E17.
3. Connector P2 pin C2 is connected to GND at the System Slot only.
4. Connector P1 pins C4, C8, C16, C20, C24 are connected to V(I/O) internal switch. For 5V the switch must be in the low position (5) and for 3.3V the switch must be in the high position (3.3).
5. Connector P1 pin D21 is connected to M66EN internal switch. For 33 MHz **only** the switch must be in the high position (33, M66EN grounded) and for 33 or 66 MHz the switch must be in the low position (66, M66EN open). Older crates can be modified to add this switch on request.
6. The V(I/O) and M66EN internal switches are accessible from the right side of the box through the module cooling air inlets (see Figure 2.1).

### 3.5. Environmental

#### 3.5.1. Environmental Specifications

Operating Location	Indoor use
Operating Temperature	0° to 50° C
Storage Temperature	-40° to 71° C
Operating Relative Humidity	5 to 95% non-condensing
Operating Altitude	3000 m

#### 3.5.2. Safety

Conformity	IEC 61010-1:2001 / EN61010-1:2001 in accordance with the European Council Low Voltage Directive 2006/95/EC Canada: CSA C22.2 No. 61010-1:2004 USA: UL 61010-1:2004 Installation Category II, Pollution Degree 2 Safety Class 1
------------	--

#### 3.5.3. EMC Immunity & Emissions

Conformity	Complies with European EMC Directive 2004/108/EC <ul style="list-style-type: none"> <li>• IEC/EN 61326-2-1</li> <li>• CISPR Pub 11 Group 1, class A</li> <li>• AS/NZS CISPR 11</li> <li>• ICES/NMB-001</li> </ul> <p>This ISM device complies with Canadian ICES-001. Cet appareil ISM est conforme à la norme NMB-001 du Canada.</p>
------------	---

Reference Standards	Limit
CISPR 11:2003 / EN 55011:2007	Class A, Group1
IEC 61000-4-2:2001 / EN 61000-4-2	4 kV/4 kV contact/air
IEC 61000-4-3:2002 / EN 61000-4-3	3 V/m, 80-2000 MHz, 1 V/m, 2-2.7 GHz
IEC 61000-4-4:2004 / EN 61000-4-4	0.5 kV signal lines, 1 kV power lines.
IEC 61000-4-5:2001 / EN 61000-4-5	0.5 kV line-line, 1 kV line-ground
IEC 61000-4-6:2003 / EN 61000-4-6	3 V, 0.15-80 MHz
IEC 61000-4-11:2004 / EN 61000-4-11	100% dip, 1 cycle; 60% dip, 10 cycles; 30% dip 25 cycles; 100% interruption, 250 cycles

The product was tested in a typical configuration with Agilent Technologies test systems.

### 3.6. Mechanical

#### 3.6.1. Mechanical Specifications

Overall Dimensions	Width: 342mm (13.47 in.) Depth: 346mm (13.63 in.) Height: including the feet <b>CC103:</b> 106mm (4.17 in.) <b>CC105:</b> 146mm (5.75 in.) <b>CC108:</b> 212mm (8.35 in.)
Overall Dimensions with Rack-mount Adapter	Width with adapter: 482.6mm (19 in.) Depth with handles: 385.0mm (15.16 in.) Height with adapter: <b>CC103 with XC103:</b> 3U, 132.5mm (5.22 in.) <b>CC105 with XC105:</b> 4U, 177.0mm (6.97 in.) <b>CC108 with XC108:</b> 5U, 221.4mm (8.72 in.)
Weight	<b>CC103:</b> 6.8 kg (15.0 lb.) <b>CC105:</b> 7.3 kg (16.1 lb.) <b>CC108:</b> 8.5 kg (18.8 lb.) <b>CC108-800:</b> 11.3 kg (24.8 lb.)
Materials	Enclosure: Steel sheet Aluminum extrusion Covers: Polystyrene (UL 94V0 rated) Card Guides: Molded plastic (UL 94V0 rated)
Finish	Enclosure: Zinc plated and exterior painted Alodine (conductive)

### 3.6.2. Dimensions

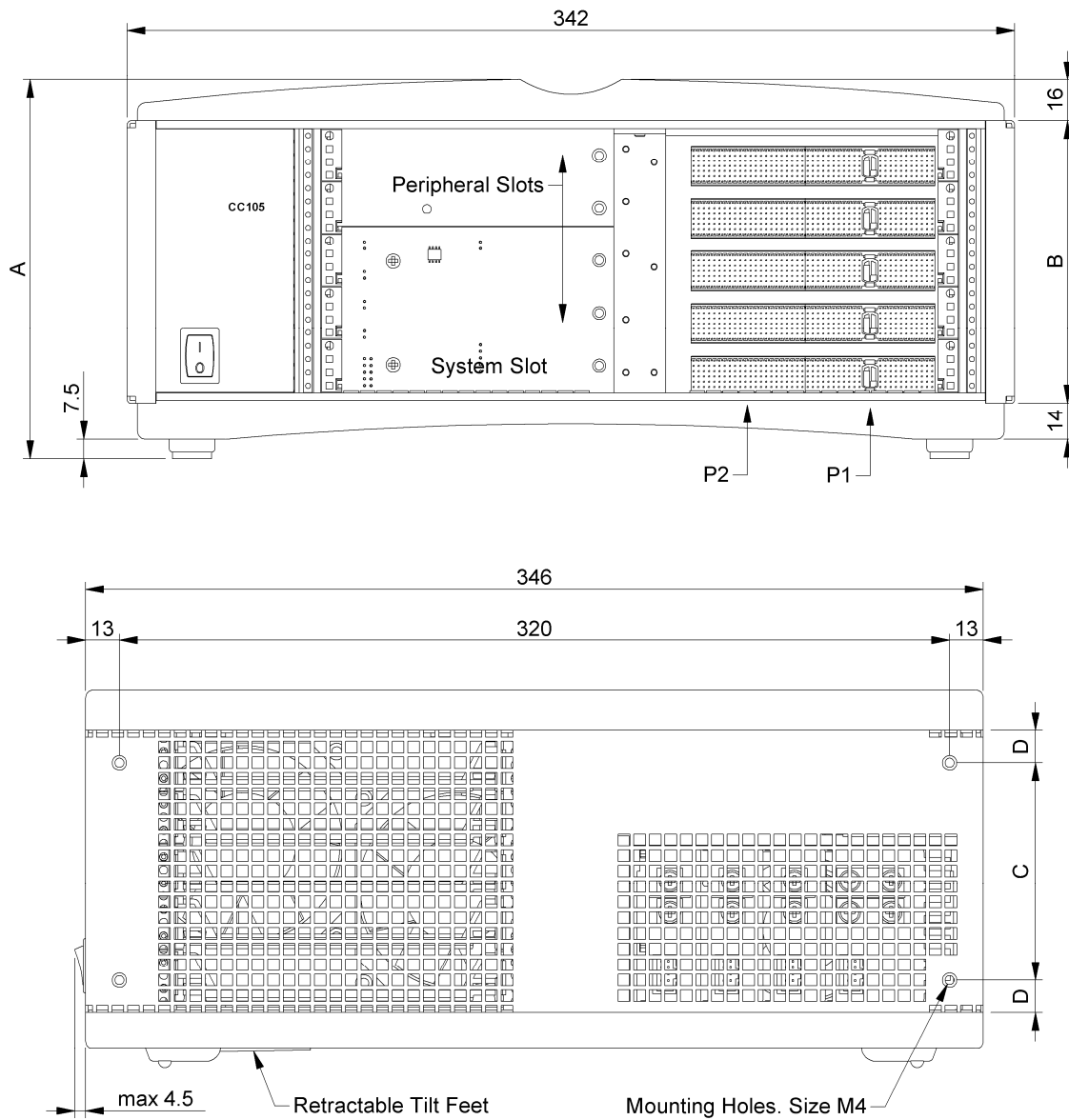

All dimensions in mm

	Slots	A	B	C	D
CC103	3	106	68.3	42	13.15
CC105	5	146	108.9	84	12.45
CC108	8	212	174.9	150	12.45

**NOTE :** The front and rear mounting holes M4 are symmetrical.

### 3.6.3. Rack Mounting Dimensions

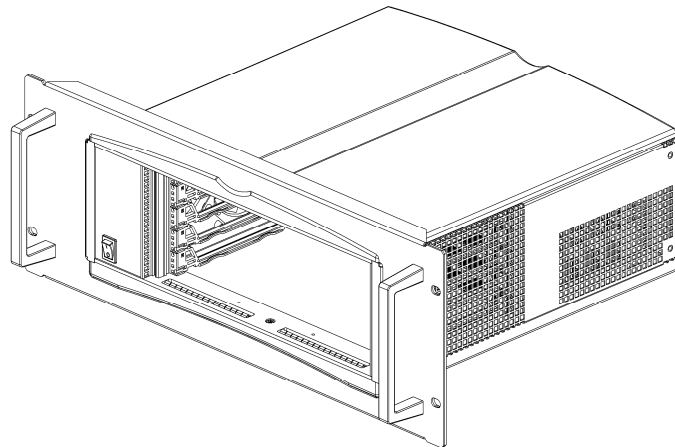
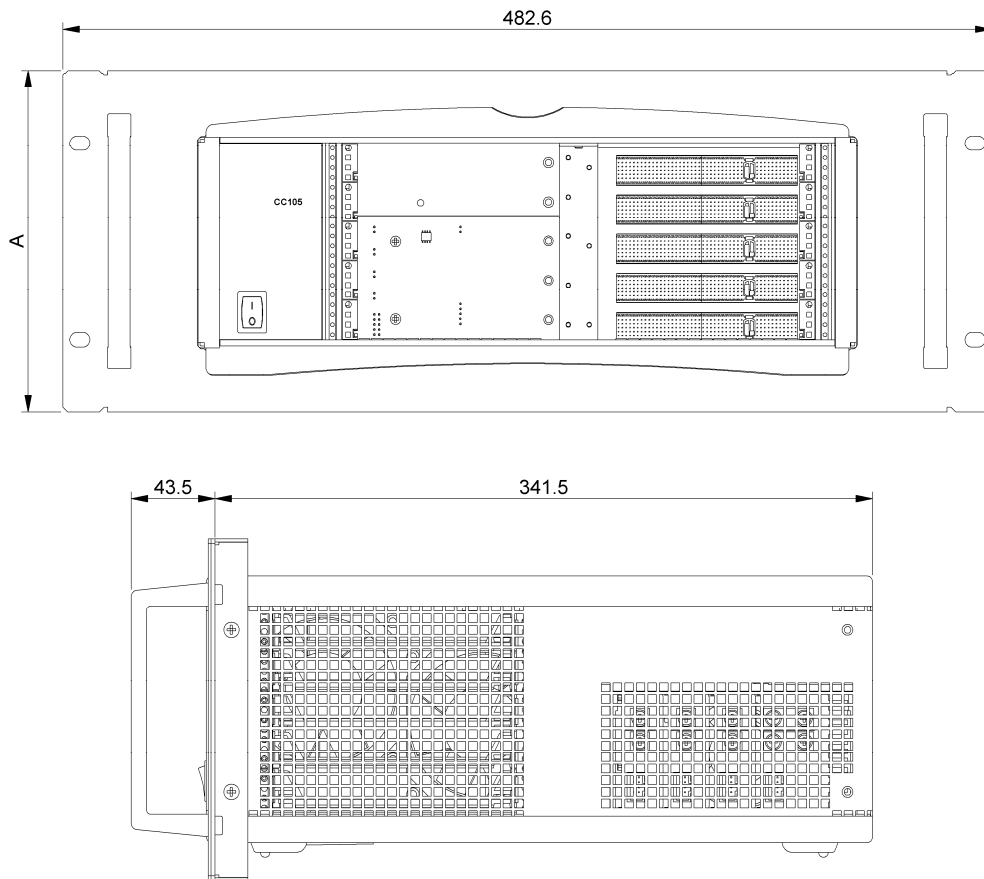

Figure 4.1: CC105 Crate with Rack-mount



All dimensions in mm

	<b>Rack-mount</b>	<b>Height</b>	<b>A</b>
<b>CC103</b>	XC103	3U	132.5
<b>CC105</b>	XC105	4U	177.0
<b>CC108</b>	XC108	5U	221.4

## 4. APPENDICES

### 4.1. U1092A-C31 XC103 Rack-mount Adapter

#### Assembly Instructions

The XC103 adapter is a universal adapter allowing the CC103 crate to be mounted in a standard 19 inch rack, with the rackmount attached to either the front or the back of the crate.

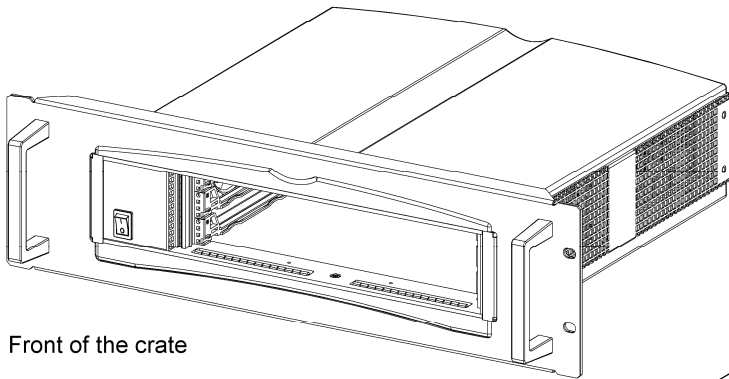

Front of the crate

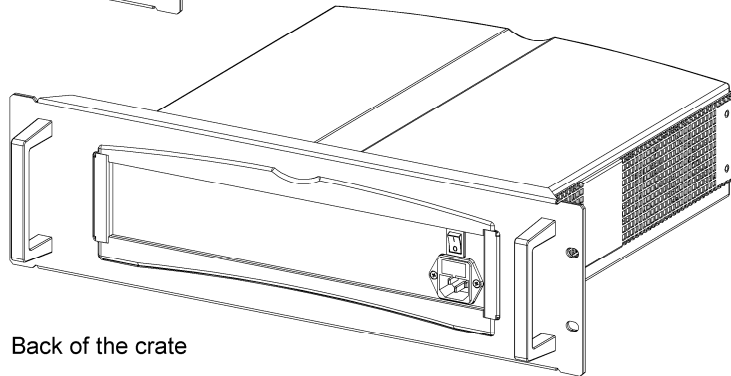

Back of the crate

The following steps are needed in order to attach the XC103 rackmount adapter to a CC103 crate.

1. Slightly loosen the four screws A.
2. Slide the crate into the rear of the rackmount, and attach with the four screws B, delivered with the kit.
3. Center the crate into the rackmount opening and tighten the screws A and B.

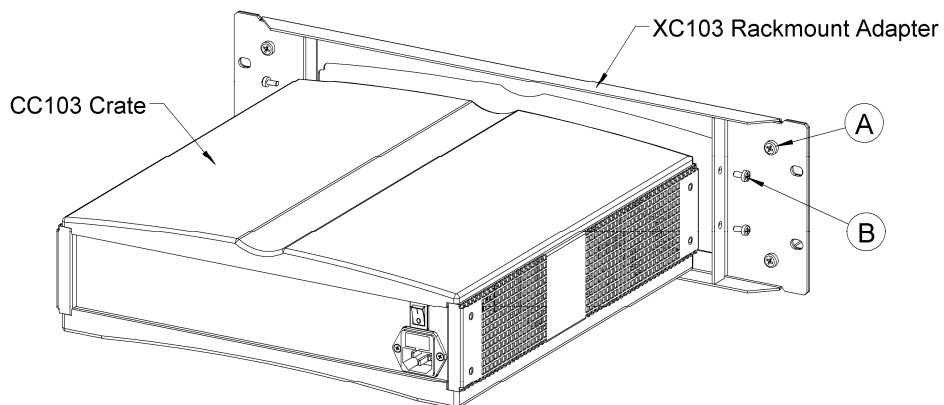

## 4.2. U1092A-C51 XC105 Rack-mount Adapter

### Assembly Instructions

The XC105 adapter is a universal adapter allowing the CC105 crate to be mounted in a standard 19 inch rack, with the rackmount attached to either the front or the back of the crate.

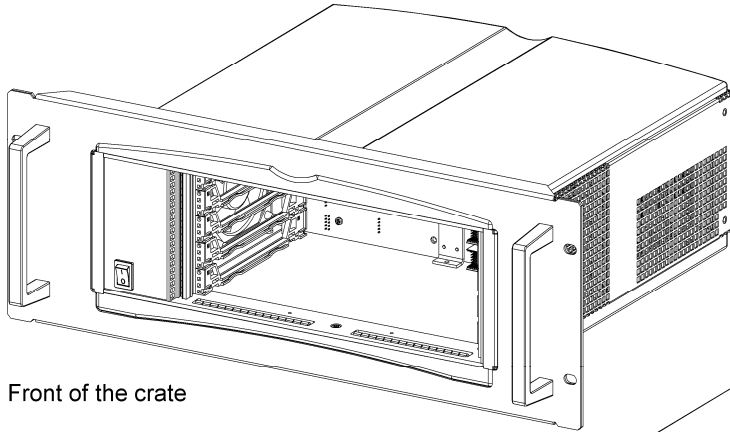

Front of the crate

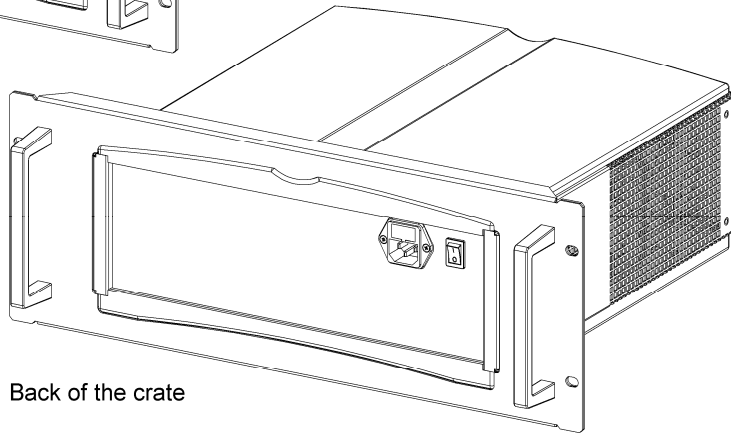

Back of the crate

The following steps are needed in order to attach the XC105 rackmount adapter to a CC105 crate.

1. Slightly loosen the four screws A.
2. Slide the crate into the rear of the rackmount, and attach with the four screws B, delivered with the kit.
3. Center the crate into the rackmount opening and tighten the screws A and B.

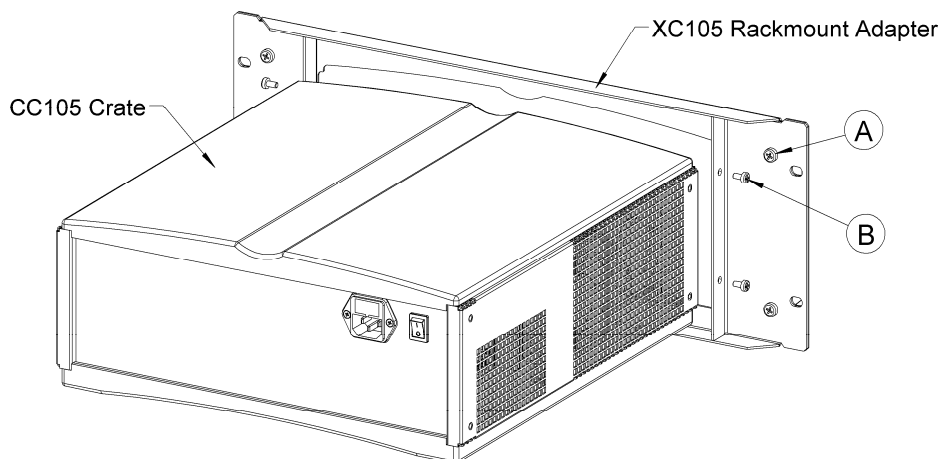

### 4.3. U1092A-C81 XC108 Rack-mount Adapter

#### Assembly Instructions

The XC108 adapter is a universal adapter allowing the CC108 crate to be mounted in a standard 19 inch rack, with the rackmount attached to either the front or the back of the crate.

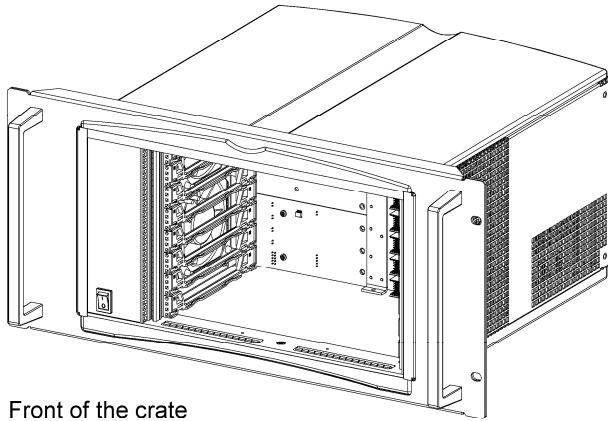

Front of the crate

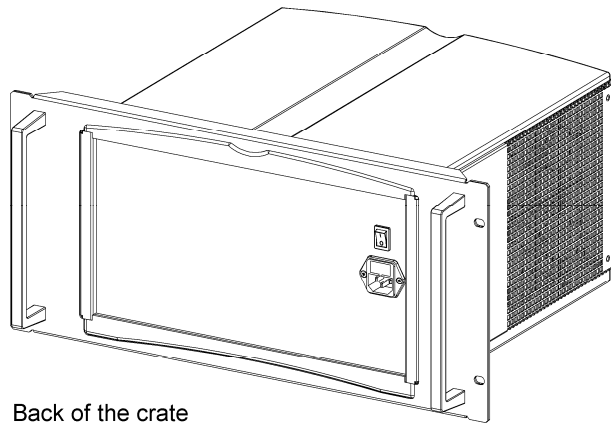

Back of the crate

The following steps are needed in order to attach the XC108 rackmount adapter to a CC108 crate.

1. Slightly loosen the four screws A.
2. Slide the crate into the rear of the rackmount, and attach with the four screws B, delivered with the kit.
3. Center the crate into the rackmount opening and tighten the screws A and B.

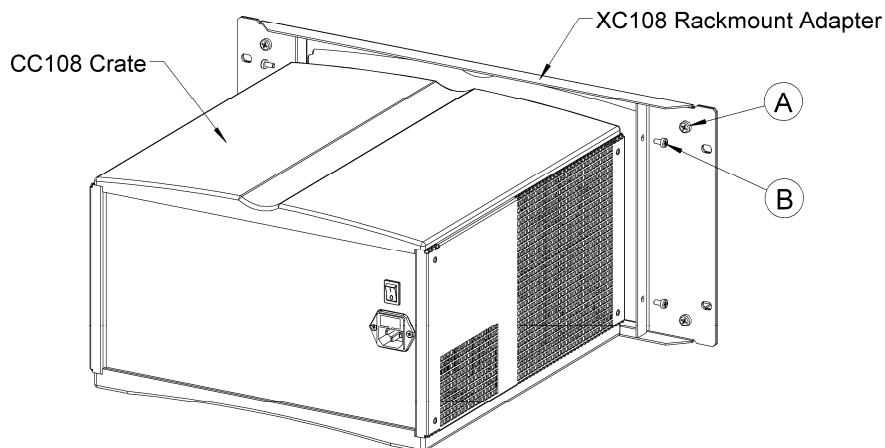



#### 4.4. XC114 – XC116 –XC119 Handles for Rack Mounted CC10X Crate Family

##### Assembly Instructions

The handles XC114, XC116, and XC119 are designed for use with the 19" rack mount adapters XC103, XC105, and XC108 and the CC103, CC105, and CC108 crates, respectively. They make it easy to carry the crate and to mount it in a rack. They can be left on the units permanently since they do not interfere with the cooling air circulation.

CC103 with XC103 and XC114

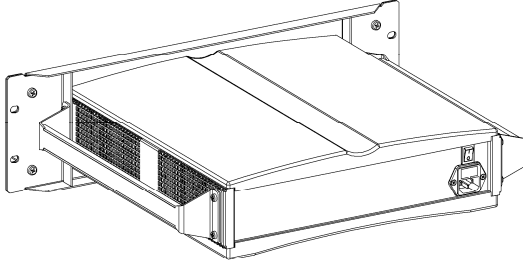

CC108 with XC108 and XC119

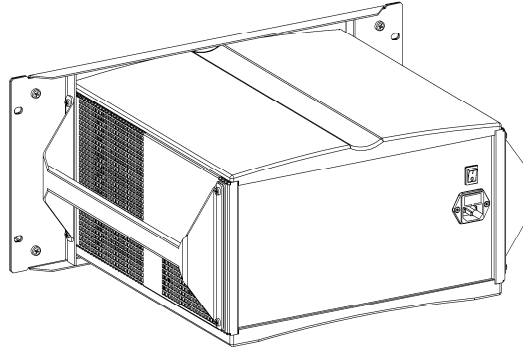

CC105 with XC105 and XC116

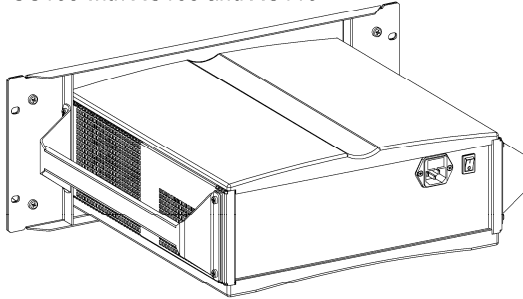

##### ASSEMBLY INSTRUCTIONS :

The kit consists of two handles, two spacers, and eight black M4x8 screws.

1. On one side of the crate, remove the two screws that hold the adapter to the crate. Using the same two screw holes and two of the M4x8 screws, fasten the handle and the adapter to the crate.
2. After inserting a spacer between the other end of the handle and the crate, use another two of the M4x8 screws to fasten the handle to the crate.
3. Repeat these operations for the second handle on the other side of the crate.

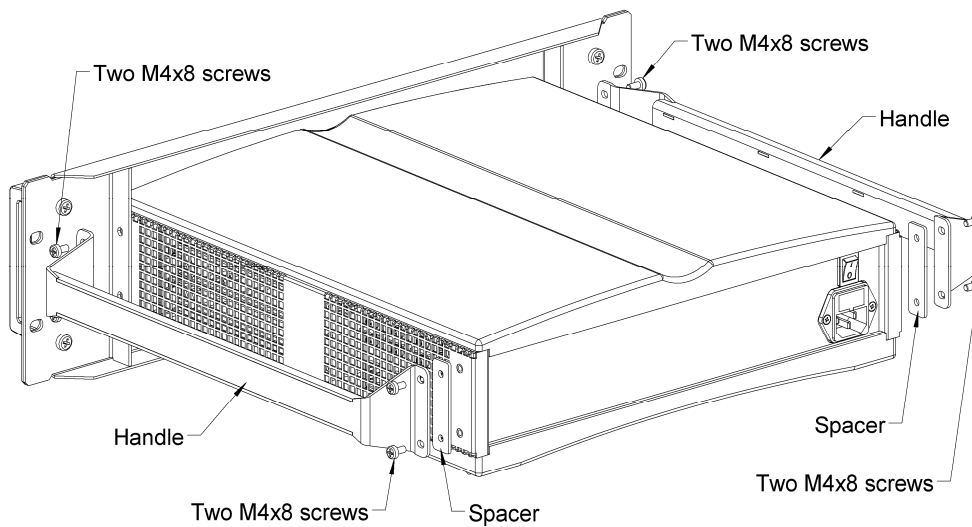

## 4.5. U1092A (U1056A)-C32 -C52 -C82 XC113 – XC115 –XC118 Handles and Feet

### Specifications and Assembly Instructions

#### SPECIFICATIONS :

The handle and feet assemblies U1092A-C32, U1092A-C52, and U1092A-C82 are designed for use with the crates U1091AC30, U1091AC50, and U1091AC80 or U1091AC83, respectively.

When they are installed it is safe and easy to carry the crates and to stand them on their sides. They can be left on the units permanently since they do not interfere with the cooling air circulation.



#### WARNING :

**The U1091 family crates have not been designed to function when they are standing on their sides. Users must accept the responsibility for using them in that position. The following points must be respected to avoid electrical shock and/or damage to the crate :**

- Make sure that the crate rests stably on the surface supporting it.
- Make sure that the upper and lower ventilation openings are not obstructed.
- Make sure that no objects can accidentally fall into nor fluids spill into the crate.

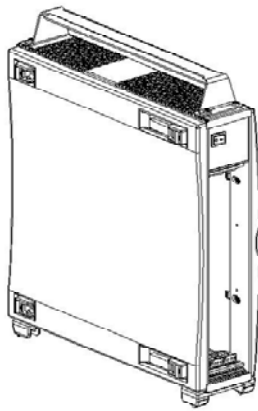

U1091AC30 with U1092A-C32 kit

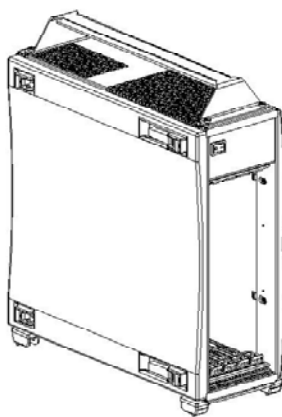

U1091AC50 with U1092A-C52 kit

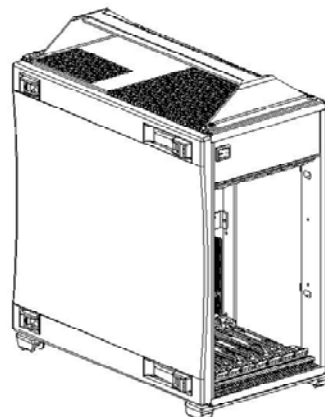

U1091AC80 or U1091AC83  
with U1092A-C82 kit

#### ASSEMBLY INSTRUCTIONS :

The kit consists of one handle, two feet, and eight black M4x8 screws.

1. Use four of the M4x8 screws to fasten the two feet to the right side of the crate, on the side opposite to the mains power switch. Make sure that the feet do not stick out in front or in back of the unit.
2. Use four of the M4x8 screws to fasten the handle to the left side of the crate.

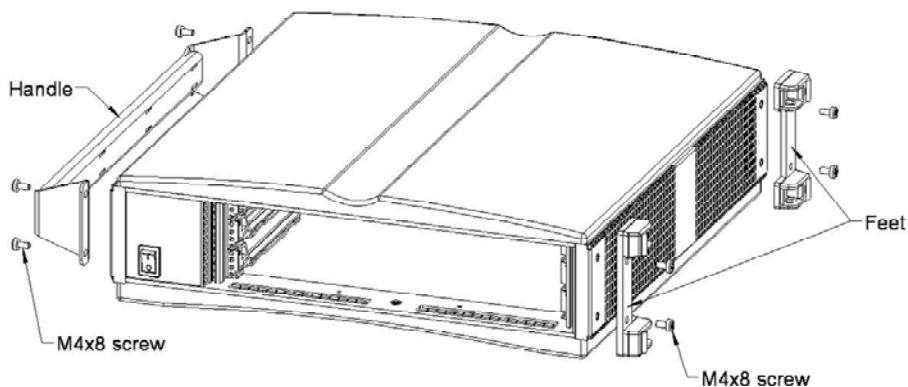

## 4.6. U1092A-C01 (U1056A-A10) XC100 6U to 3U Slot Adapter

### Specifications and Assembly Instructions

#### **SPECIFICATIONS :**

The XC100 6U to 3U slot adapters are specially designed for use with Acqiris CompactPCI crates. The XC100 allows the use of 3U CompactPCI modules in any vacant 6U slot.

#### **CAUTION :**

The XC100 6U to 3U slot adapter must be installed prior to inserting any 3U CompactPCI module into any Acqiris CompactPCI crate. The XC100 assures proper mechanical alignment when inserting a 3U module and protects the crate's backplane connectors from damage. In addition, the XC100 provides the function of a blanking panel to completely close the vacant slot. This function is essential to guarantee EMC shielding and adequate cooling.

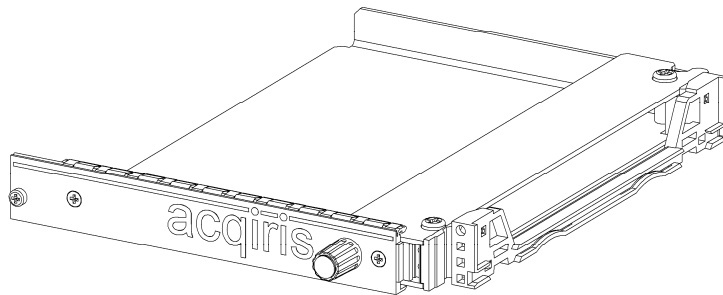

#### **ASSEMBLY INSTRUCTIONS :**

1. Insert the XC100 into the left part of the chosen 6U slot.
2. Turn knob "A" in the clockwise direction to fasten the unit into place.
3. Fasten screw "B" to insure proper grounding of the frame.

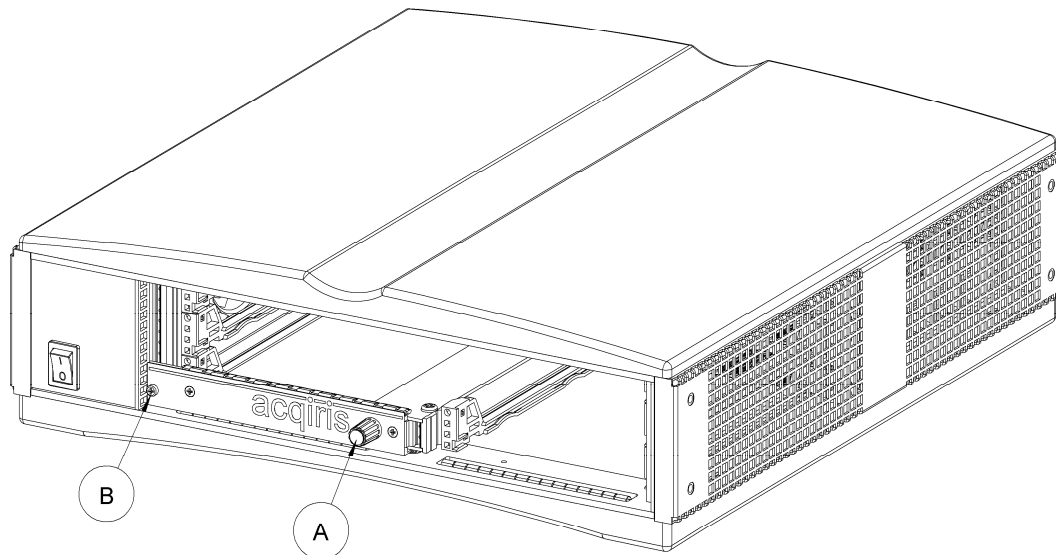

## 4.7. U1092A-C02 (U1056A-A11) XC200 6U Filler Plug-in

### Specifications and Assembly Instructions

#### SPECIFICATIONS :

The XC200 filler plug-in is used to close vacant slots in Acqiris' 6U CompactPCI Crates.

#### CAUTION :

The XC200 filler panel is required to guarantee EMC shielding and adequate cooling. Crates should not be used without closing all vacant front panel slots.

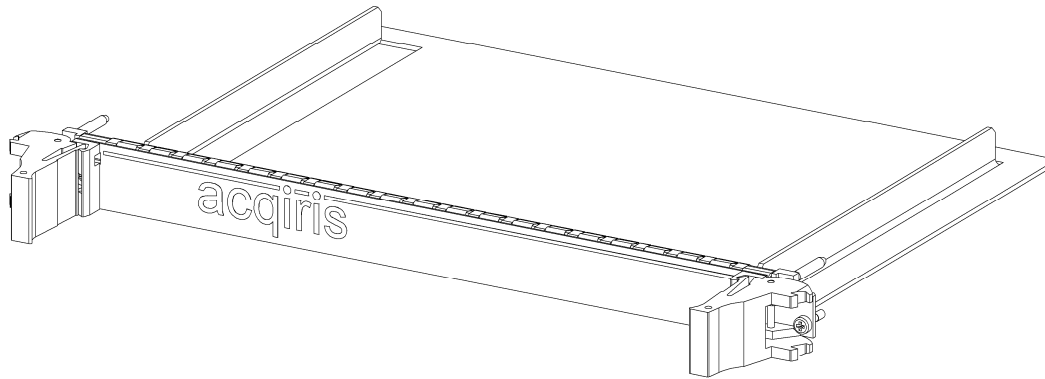

#### ASSEMBLY INSTRUCTIONS :

1. Insert the XC200 in the chosen slot by holding the handles on each side.
2. Gently push the XC200 into the slot and secure it by clipping the handles into place.
3. Tighten both screws "A" to lock the XC200 into place and insure proper grounding of the frame.

